

Submittal Data: 24RLXFZH
Inverter Driven Heat Pump

24,000 BTU Multi-Zone System

Job Name: _____

Date: _____

Location: _____

Approval: _____

Engineer: _____

Construction: _____

Submitted to: _____

Unit #: _____

Submitted by: _____

Drawing #: _____

Reference: _____

General Features

- Refrigerant Type R410A.
- Extra long piping allotment
- Wired and wireless remote controllers
- Automatic airflow adjustment
- Economy operation
- Base pan heater
- 5- Years Parts, 7-Years Compressor Warranty (See Warranty Statement for details)
- 24 hr. Timer
- Low operating temperature

Model Information

Condenser..... AOU24RLXFZH
Evaporator*1..... (ASU) / (ARU) / (AGU) / (AUU) 7,9,12RLF(1)
Connectable indoor units..... 2 - 3
Total capacity range..... 14,000 – 27,000 Btu/h

Electrical..... 208/230V AC 1ph-60Hz
Available Voltage Range..... 208/230 +/- 10%
Minimum Circuit Ampacity..... 25.1 A
Max Fuse Size..... 30 A
Max Starting Current..... 8.3 A

Input Power

Cooling..... (non-duct) 1.65 kW / (ducted) 1.81 kW / (mix) 1.74 kW
Heating..... (non-duct) 1.81 kW / (ducted) 1.89 kW / (mix) 1.85 kW

Current

Cooling..... (non-duct) 7.2 A / (ducted) 7.9 A / (mix) 7.6 A
Heating..... (non-duct) 7.9 A / (ducted) 8.3 A / (mix) 8.1 A

Capacity

Nominal Cooling..... 22,000 Btu/h
Min-Max Cooling..... 6,100 – 27,000 Btu/h
Nominal Heating..... 25,000 Btu/h
Min-Max Heating..... 6,800 – 29,800 Btu/h

Compressor

..... Rotary (inv x1)
Motor Output..... 2,100 W
Refrigerant..... R410a
Charge..... 4 lbs. 14 oz
Oil..... RB68

Fan Motor

(Condenser) Type: DC Propeller x1
(Condenser) Motor Output..... 100 W
(Evaporator) Type: DC..... (wall-mount) Cross flow
(compact cassette) Turbo
(ducted) Sirocco
(floor) Cross flow x2
(Evaporator) Motor Output..... (wall) 30W-42W (compact cassette) 54W (ducted) 80-81W

Heat Exchanger

Dimensions
(H x W x D) in. (mm)..... 31-7/16 x 35-7/16 x 1-7/16 (798x900x36.38)
Fin Pitch..... 20 FPI
Rows x Stages..... 2 x 38
Pipe Type (Material)..... Copper
Fin Type (Material)..... Aluminum



Operation Temperature Range

Cooling..... 14°F - 115°F (-10°C - 46°C)
Heating..... -15°F - 75°F (-26°C - 24°C)

Efficiency

SEER*2..... (wall-mount) 20 (duct) 18 (mix) 19
EER (cooling)..... (wall-mount) 13.3 Btu/W (duct) 12.1 Btu/W (mix) 12.7 Btu/W
COP (heating)..... (wall-mount) 4.04 W/W (duct) 3.87 W/W (mix) 3.96 W/W
HSPF (heating)..... (wall-mount) 10.3 (duct) 9 (mix) 9.7

Enclosure (Condenser)

Material..... Painted galvanized steel
Color..... Beige (10 YR 7.5/1.0 NN)

Sound Pressure Level

Condenser..... 52 dB(A)

Dimensions

H x W x D
Condenser
Net in. (mm)..... 32-11/16 x 35-7/16 x 13 (830x900x330)
Gross in. (mm)..... 38-3/16 x 41-5/16 x 17-1/2 (970x1,050x445)

Connection Pipe

Liquid..... 1/4" x3
Gas..... 3/8" x2 + 1/2" x1
Method (Liquid/Gas)..... Brazing
Max Length (Pre-charge)..... 229ft. (70m) / (98 ft. {30m})
Max Height Difference..... 49 ft. (15m)

Weight

Condenser..... 146 lbs. (66 kg)
Evaporators..... (wall-mount) 19 lbs. - 31 lbs.
(compact cassette) 33 lbs.
(ducted) 37 lbs. - 49 lbs.
(floor) 31 lbs.

Accessories

Wired Remote Controller..... UTY-RVNUM
Wired Remote Controller..... UTY-RNNUM
Simple Remote Controller..... UTY-RSNUM

*1 Reference brochure for approved combinations. *2 Test conditions are based on AHRI 210/240.
Note: Specifications are based on the following conditions. Cooling: Indoor temperature of 80°F (26.7°C) DB/67°F (19.44°C) WB, and outdoor temperature of 95°F (35°C) DB/75°F (23.9°C) WB. Heating: Indoor temperature of 70°F (21.11°C) DB/59°F (15°C) WB, and outdoor temperature of 47°F (8.33°C) DB/43°F (6.11°C) WB. Pipe length: 24ft. (7.3m). Height difference: 0ft. (0m) (Outdoor unit – indoor unit)

Dimensions:24RLXFZH

[Unit: in. (mm)]

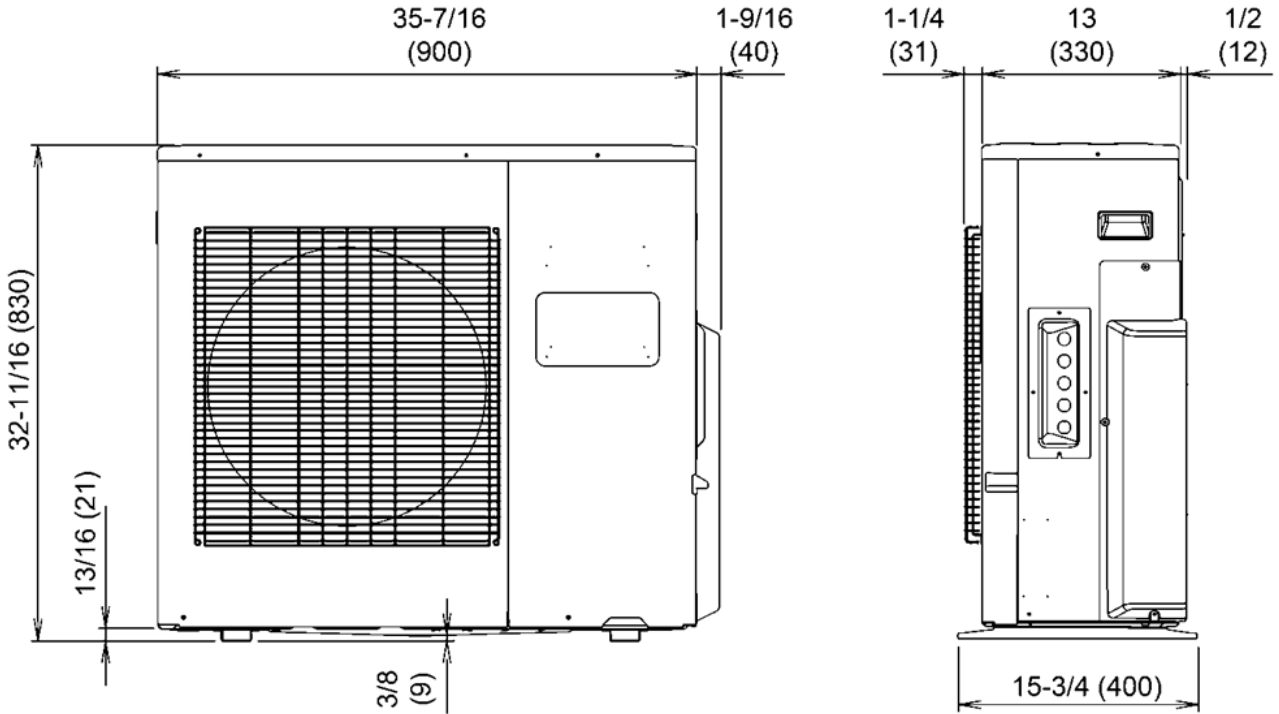

Front view

Side view

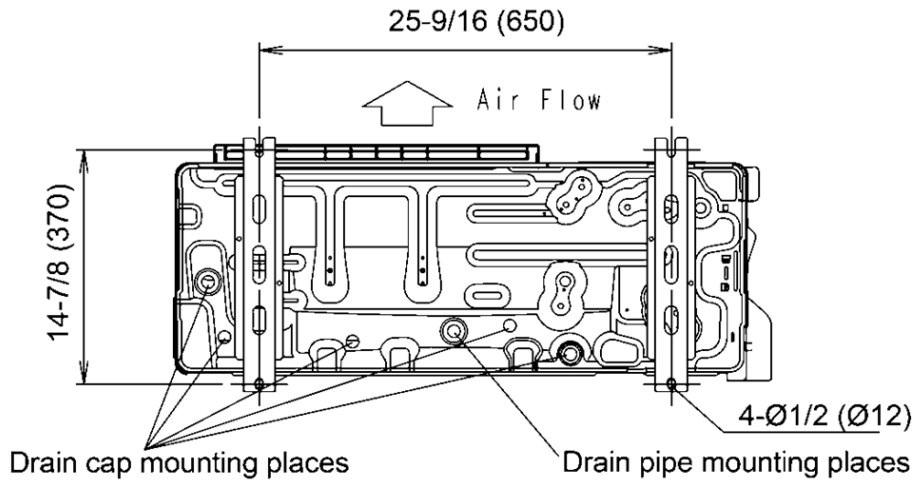

Bottom view